

THIS DRAWING IS UNPUBLISHED. RELEASED FOR PUBLICATION JAN ,2006.

© COPYRIGHT 2006 BY TYCO ELECTRONICS CORPORATION. ALL RIGHTS RESERVED.

LOC	DIST	REVISIONS					
E	B	P	LTR	DESCRIPTION	DATE	DWN	APVD
		D		ECR-06-016179	04JUL06	JMS	FWK

- NOTES:**
- 1 PACK IN ACCORDANCE WITH AMP SPEC 107-3275
 - 2 100 TRAY PACK IN ACCORDANCE WITH AMP SPEC 107-3275
 - 3 Au PLATING
- 4 **ELECTRICAL CHARACTERISTICS**
 FREQUENCY RANGE: DC - 4 GHz
 NOMINAL IMPEDANCE: 50 Ohm
 INSULATION RESISTANCE: 1000 MOhm
 WORKING VOLTAGE: 250 Volts RMS at Sea Level
 DIELECTRIC WITHSTAND VOLTAGE: 750 Volts RMS Max
 CONTACT RESISTANCE:
 CENTRE CONTACT: 6.00 mOhm Max
 OUTER CONTACT: 1.00 mOhm Max
- 5 **MECHANICAL CHARACTERISTICS**
 DURABILITY: 500 Cycles Min
- 6 **ENVIRONMENTAL CHARACTERISTICS**
 OPERATING TEMPERATURE: -65 to +165 DegC
- 7 FOR TECHNICAL DATA REFER TO YOUR LOCAL TYCO ELECTRONICS SALES OFFICE
- 8 ALL DIMENSIONS ARE NOMINAL FOR REFERENCE ONLY UNLESS OTHERWISE STATED

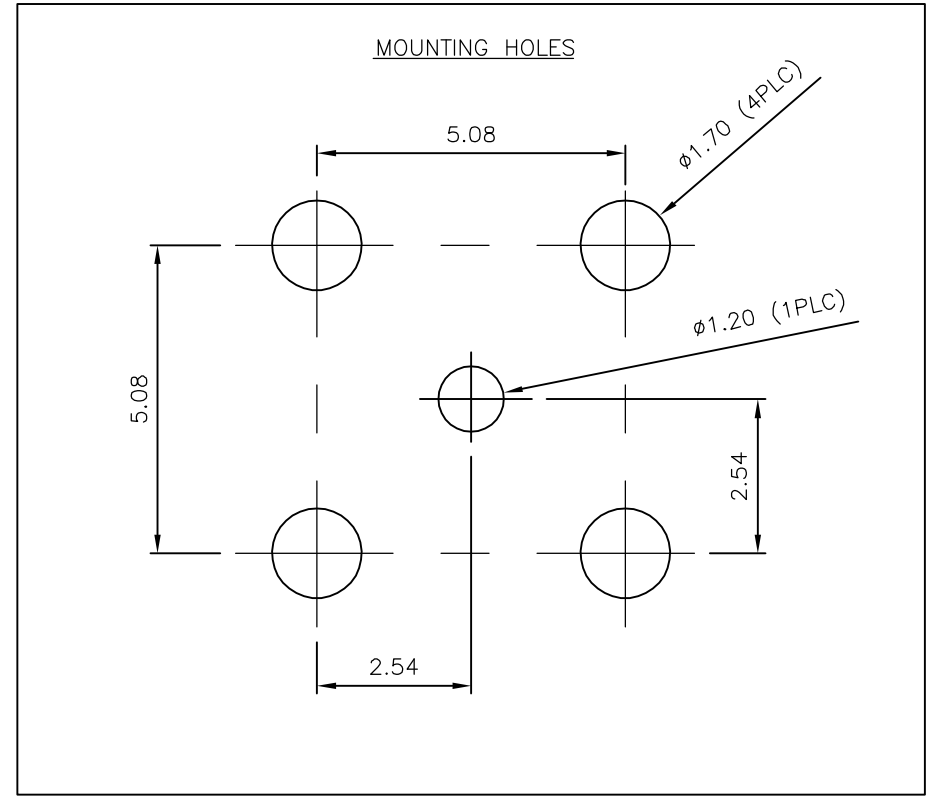
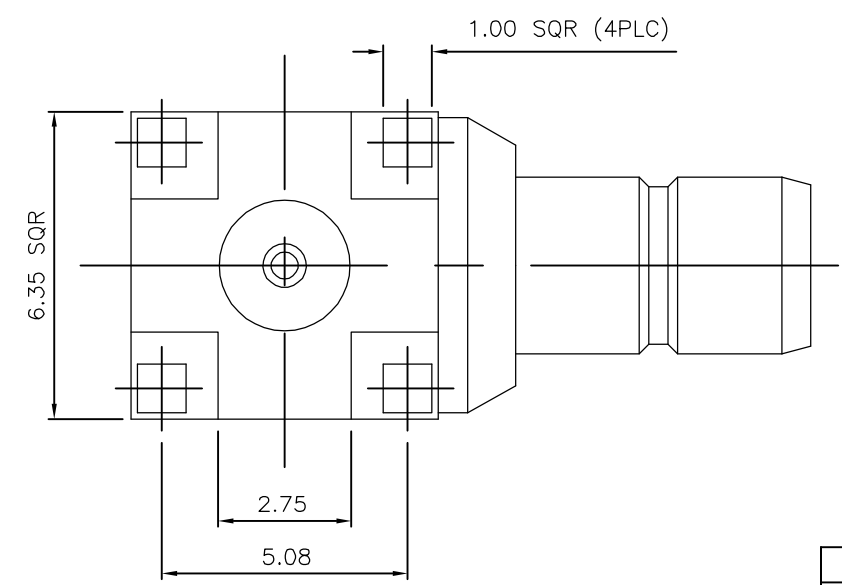
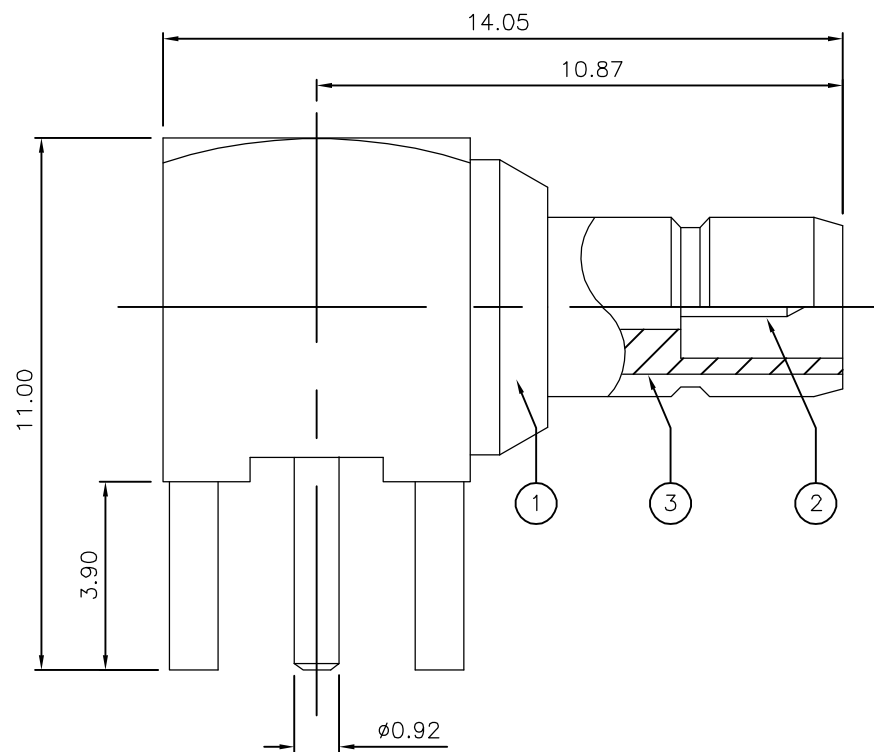

QTY	QTY	MATERIAL	DESCRIPTION	ITEM
1	1	PTFE	INSULATION	3
1	1	PHOSPHOR BRONZE	CONTACT	2
1	1	BRASS	BODY	1
6--0	1--0			

THIS DRAWING IS A CONTROLLED DOCUMENT.		DWN J.SANDWELL 12JAN06	Tyco Electronics Corporation Bideford EX39 4HE															
DIMENSIONS: mm		CHK S.PARLOW 12JAN06																
TOLERANCES UNLESS OTHERWISE SPECIFIED:		APVD F.WHEELER-KING 12JAN06	NAME SMB ELBOW PCB SOCKET 50 OHM															
<table border="1"> <tr><td>0 PLC</td><td>± -</td></tr> <tr><td>1 PLC</td><td>± -</td></tr> <tr><td>2 PLC</td><td>± -</td></tr> <tr><td>3 PLC</td><td>± -</td></tr> <tr><td>4 PLC</td><td>± -</td></tr> <tr><td>ANGLES</td><td>± -</td></tr> <tr><td>FINISH</td><td>± -</td></tr> </table>		0 PLC	± -	1 PLC	± -	2 PLC	± -	3 PLC	± -	4 PLC	± -	ANGLES	± -	FINISH	± -	PRODUCT SPEC	RESTRICTED TO	
0 PLC	± -																	
1 PLC	± -																	
2 PLC	± -																	
3 PLC	± -																	
4 PLC	± -																	
ANGLES	± -																	
FINISH	± -																	
MATERIAL SEE TABLE		APPLICATION SPEC	SIZE A3	CAGE CODE 00779														
		WEIGHT -	DRAWING NO C-1337481															
		CUSTOMER DRAWING	SCALE NTS	SHEET 1 OF 1														
			REV D															